

MICROPROFILE PICK-OFF TRANSFORMER

P2769

Features

- * Surface Mount
- * Lead-free (Pb- free)
- * RoHS compliant
- * 7mm seated height
- * Vacuum encapsulated
- * IEC 60950 and UL 60950 certified
- * UL Recognized Component

Applications

- * Telecommunications
- * Pick-off applications
- * Calling Line Identification
- * Instrumentation

DESCRIPTION

P2769 is a high impedance microprofile transformer for applications where high performance and safety isolation to international standards are required in an extremely small case size.

P2769 is designed for "listening" applications when placed across a line, presenting a very high impedance to minimize circuit loading. The part is compliant with RoHS Directive 2002/95/EC, and suitable for lead-free and conventional placement and reflow.

To meet requirements for $\geq 40k\Omega$ across the voiceband, P2769 can be used in an application circuit described herein.

P2769 is certified to IEC 60950 and UL 60950. P2769 is a UL Recognized Component, and is supported by an IEC CB Test Certificate.

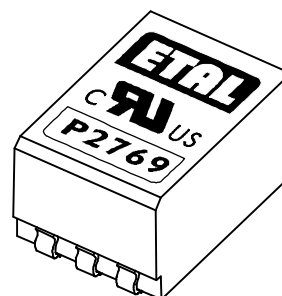

SPECIFICATIONS

Electrical

At T = 25°C and reference circuit fig.2, unless otherwise stated.

Parameter	Conditions	Min	Typ	Max	Units
Voltage isolation ⁽¹⁾	50Hz	3.88	-	-	kVrms
	DC	5.5	-	-	kV
Input impedance ⁽³⁾	200Hz – 4kHz, 1Vrms,	30	-	-	kΩ
Operating range:	Ambient temperature				
Functional		-25	-	+85	°C
Storage ⁽⁴⁾		-40	-	+125	°C
Humidity		-	-	95	%R.H.

Lumped equivalent circuit parameters as Fig. 1

DC resistance, R_{DC} ⁽²⁾	Sum of windings	-	3300	-	Ω
Leakage inductance ΔL		-	67	-	mH
Shunt inductance L_p	10mV 200Hz	20	30	-	H
Shunt loss R_p	10mV 200Hz	80	110	-	kΩ

Notes

- Components are 100% tested at 6.5 kVDC.
- Caution:** do not pass DC through windings. Telephone line current, etc. must be diverted using choke or semiconductor line hold circuit.
- For 40kΩ impedance, see fig.3.
- Excludes shipping materials. Components are dry-packed and sealed as shipped. Refer to Profec Technologies for appropriate storage conditions for sealed consignments. Handle in accordance with IPC/JEDEC J-STD-033 procedure for components classified as IPC/JEDEC J-STD-020 Moisture Sensitivity Level 5a.

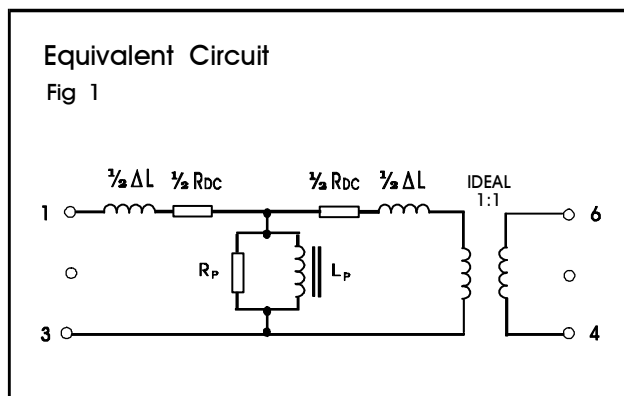

Reference Circuit

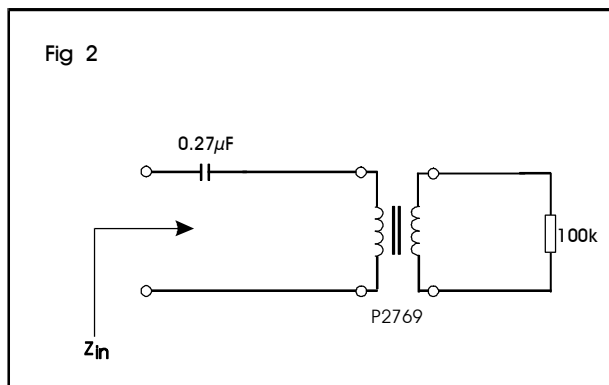

In practice, the $100k\Omega$ load can be increased without limit. The DC blocking capacitor should be a minimum of $0.22\mu F$ to avoid resonance within the voiceband to obtain a flat frequency response and input impedance to specification.

40kΩ APPLICATION CIRCUITS

For applications requiring impedance greater than $40k\Omega$ for parallel-connected Terminal Equipment (e.g. ETSI TS 103 021, $\geq 40k\Omega$, 200Hz – 4.3kHz) the following circuit may be helpful.

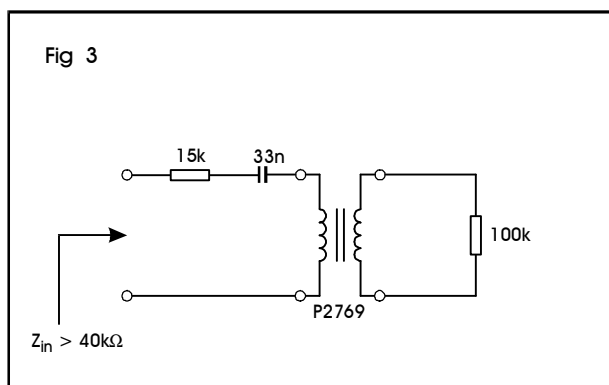

At the expense of a small loss, (approximately 1.5dBV) the circuit in fig. 3 provides an impedance exceeding $40k\Omega$, 200Hz – 4.3kHz, and frequency response flatness within $\pm 0.25dB$ over the same band.

CONSTRUCTION

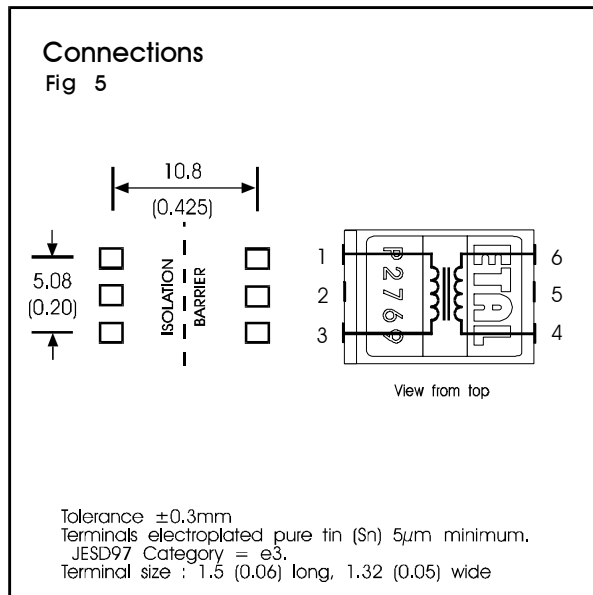
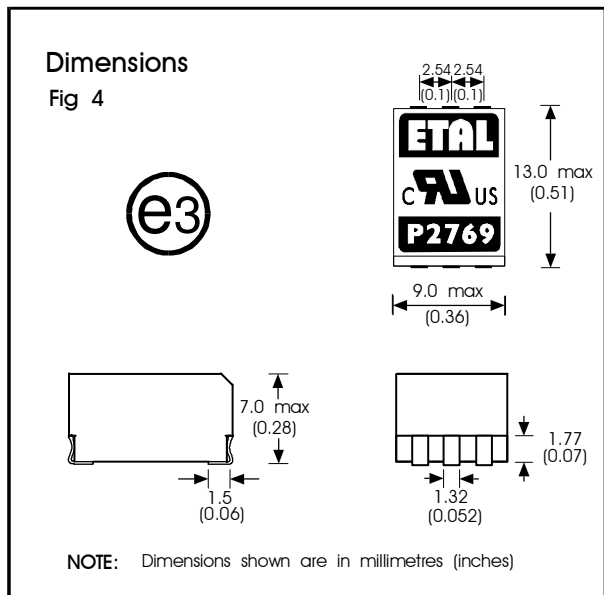

Dimensions shown are in millimetres (inches).

Geometric centres of outline and pad grid coincide within a tolerance circle of $0.3\text{mm}\varnothing$.

Windings may be used interchangeably as primary or secondary.

ABSOLUTE MAXIMUM RATINGS

(Ratings of components independent of circuit).

Short term isolation voltage (2s)	4.6kVrms, 6.5kVDC
DC current	100 μA
Storage temperature	-40 $^{\circ}\text{C}$ to +125 $^{\circ}\text{C}$
Soldering temperature Profile peak	260 $^{\circ}\text{C}$ 10s
Recommended peak body temperature in accordance with IPC/JEDEC J-STD-020	245 $^{\circ}\text{C}$

COPYRIGHT

ETAL and P2769 are Trade Marks of Profec Technologies Ltd.

The Trade Mark ETAL is registered at the UK Trade Marks Registry.

Profec Technologies Ltd. is the owner of the design right under the Copyright Designs and Patents Act 1988 and no rights or licences are hereby granted or implied to any third party.

British Patent No. 2283195

US Patent No. 5879598

European Patent No. 0725719

© 1997 - 2007 Profec Technologies Ltd.
 Reproduction prohibited.

SAFETY

Manufactured from materials conforming to flammability requirements of UL94V-0.

Distance through reinforced insulation 0.4mm minimum.

Creepage and clearances in circuit are 7mm minimum where PCB pads do not exceed 3mmØ.

Construction complies with IEC 60950-1, EN 60950-1 and UL 60950-1, reinforced insulation, 250Vrms maximum working voltage.

CERTIFICATION

Certified by BSI to IEC 60950 Third Edition (1999) (IEC CB Test Certificate No. GB592W) sub-clauses 1.5, 1.5.1, 1.5.2, 2.9, 2.9.1, 2.9.2, 2.9.3, 2.9.4, 2.9.5, 2.10, 2.10.1, 2.10.2, 2.10.3, 2.10.3.1, 2.10.3.2, 2.10.4, 2.10.5, 2.10.5.1, 2.10.7, 2.10.8, 4.7, 4.7.3, 4.7.3.1, 4.7.3.4, (Flammability Class V-0) 5.2, 5.2.1, and 5.2.2 for a maximum working voltage of 250Vrms, nominal mains supply voltage not exceeding 250Vrms and a maximum operating temperature of +85°C in Pollution Degree 2 environment, reinforced insulation.

Recognized under the Component Recognition Program of Underwriters Laboratories Inc. to US and Canadian requirements CAN/CSA C22.2 No. 60950-1-03/UL60950-1, First Edition, based on IEC 60950-1, First Edition, maximum working voltage 250Vrms, Pollution Degree 2, reinforced insulation.

UL File number E203175.

Additionally, Profec Technologies certifies all transformers as providing voltage isolation of 3.88kVrms, 5.5kV DC minimum. All shipments are supported by a Certificate of Conformity to current applicable safety standards.

ORDERING CODE

P2769□□



TR = Tape and Reel
(Blank) = Bulk in tubes.

Carrier tape width 24mm,
500 parts per 13" reel.



ISO 9001
FM 25326

Profec Technologies Ltd., 10 Betts Avenue, Martlesham Heath, Ipswich, IP5 3RH, England

Telephone: +44 (0) 1473 611422

Website: www.profec.com

Fax: +44 (0) 1473 611919

Email: info@profec.co.uk sales@profec.com