

MICROPROFILE LINE MATCHING TRANSFORMER

P2782

Features

- * Surface Mount
- * Lead-free (Pb-free)
- * RoHS compliant
- * 7mm seated height
- * Vacuum encapsulated
- * IEC 60950 and UL 60950 certified
- * UL Recognized Component
- * Centre-tapped winding

Applications

- * Telecommunications
- * V.22bis modems
- * Line matching
- * Portable computers
- * Instrumentation

DESCRIPTION

P2782 is a microprofile transformer with one centre-tapped winding for applications where high performance and safety isolation to international standards are required in an extremely small case size.

Designed specifically as a surface mount device, the P2782 features a 7mm seated height and is vacuum encapsulated and tested to 6500VDC. The part is compliant with RoHS Directive 2002/95/EC, and suitable for lead-free and conventional placement and reflow.

Despite the subminiature size, the performance is the equal of that of much larger components. The P2782 offers reinforced insulation, is ideal for voice telecommunications and for data communications to V.22bis (2,400 bits/second), and can be matched to both 600Ω and complex impedance telephone lines.

At moderate transmit power levels (e.g. -10dBm) performance to V.32bis may be achieved.

In instrumentation applications, the P2782 offers a wideband frequency response from 50Hz to 40kHz.

P2782 is certified to IEC 60950 and UL 60950. P2782 is a UL Recognized Component, and is supported an IEC CB Test Certificate.

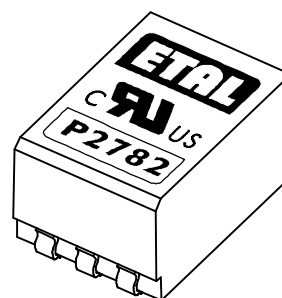

SPECIFICATIONS

Electrical

At T = 25°C and as circuit Fig. 1 unless otherwise stated.

Parameter	Conditions	Min	Typ	Max	Units
Insertion Loss	f = 2kHz, R _L = 600Ω	-	-	2.0	dB
	f = 2kHz, R _L = 430Ω	-	-	4.0	dB
Frequency response	-3dB LF cutoff	-	50	-	Hz
	-3dB HF cutoff	-	40	-	kHz
	200Hz - 4kHz	-	-	±0.2	dB
Return Loss	200Hz - 4kHz	18	-	-	dB
Distortion ⁽¹⁾	f = 450Hz 0dBm in line 3rd Harmonic	-	-60	-54	dBm
Balance	DC - 5kHz Method TG25	80	-	-	dB
Saturation	Excitation 50Hz 250Vrms	-	-	10	Vrms
	Output voltage across line	-	-	65	Vpeak
Voltage Isolation ⁽²⁾	50Hz	3.88	-	-	kVrms
	DC	5.5	-	-	kV
Operating range:	Ambient temperature	-	-	-	-
Functional Storage ⁽⁶⁾		-25	-	+85	°C
Humidity		-40	-	+125	°C
		-	-	95	%R.H.

Lumped equivalent circuit parameters as Fig. 1

DC resistance, R _{DC} ^{(3) (5)}	Sum of windings	205	-	245	Ω
Leakage inductance ΔL		4.2	-	4.9	mH
Shunt inductance L _p ⁽⁴⁾	10mV 200Hz	1.4	-	3.5	H
	10mV 1kHz	-	1.8	-	H
Shunt loss R _p ⁽⁴⁾	10mV 200Hz	5	-	15	kΩ
	10mV 1kHz	-	10	-	kΩ

Notes

- Third harmonic typically exceeds other harmonics by 20dB.
- Components 100% tested at 6.5 kVDC.
- Caution:** do not pass DC through windings. Telephone line current, etc. must be diverted using choke or semiconductor line hold circuit.
- At signal levels greater than 100mV, L_p will increase and R_p will decrease slightly but the effect is usually favourable to the return loss characteristic.
- Resistance imbalance between the two halves of the tapped winding will not be greater than 7Ω.
- Excludes shipping materials. Components are dry-packed and sealed as shipped. Handle in accordance with IPC/JEDEC J-STD-033 procedure for components classified as IPC/JEDEC J-STD-020Moisture Sensitivity Level 5a.

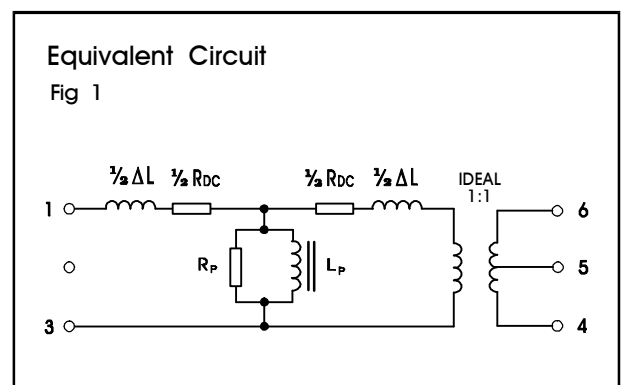

PERFORMANCE

600Ω MATCH

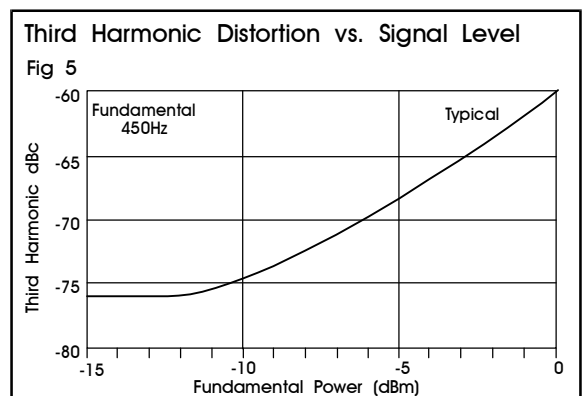
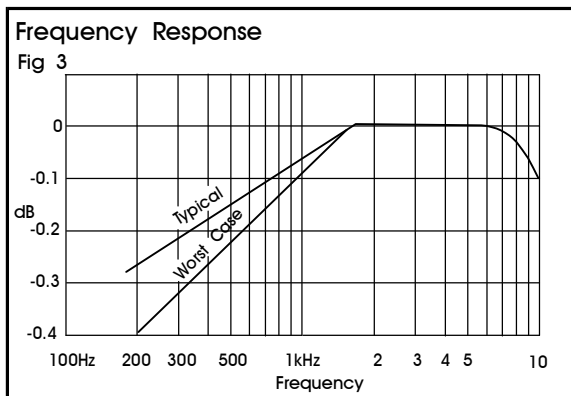
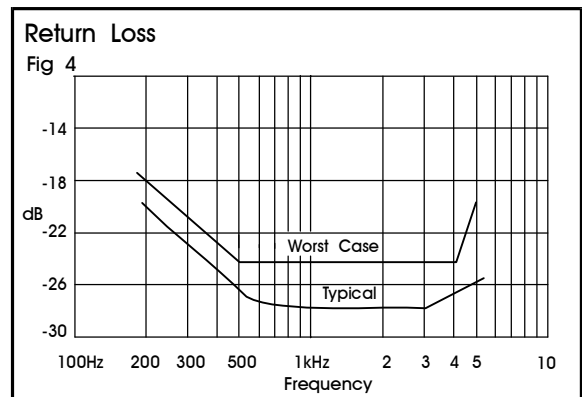
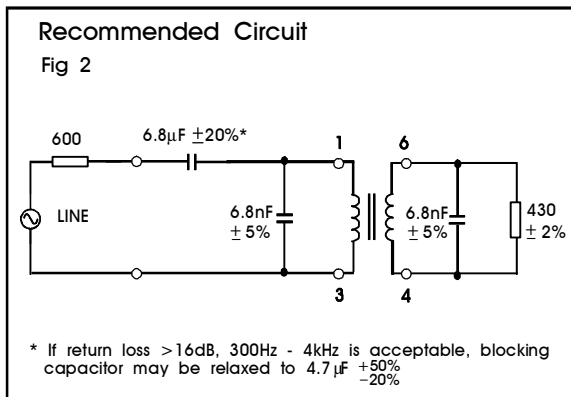

Frequency response driven by terminal equipment (voltage source with 430Ω series resistance) measured across 600Ω is within ± 0.2 dB 200Hz to 4kHz

Note:
To obtain harmonic distortion power in dBm, add fundamental power in dBm to third harmonic in dBc e.g. at -10dBm power in line at 450Hz, third harmonic power is $-10 + (-74) = -84$ dBm typical.

EUROPEAN CTR21 COMPLEX MATCH

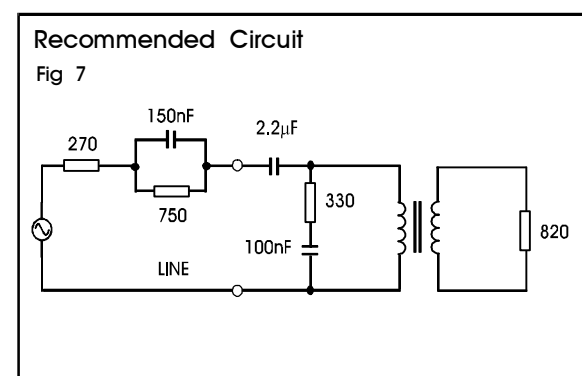
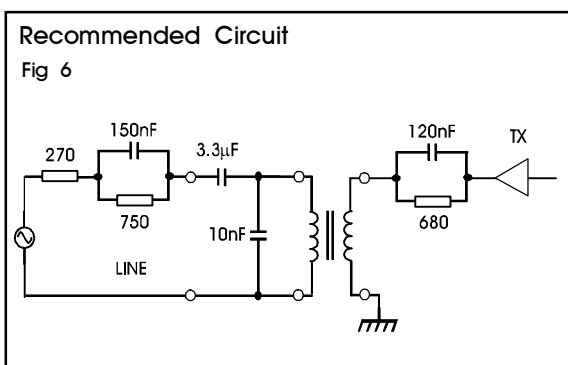

The circuit of Fig. 6 gives good TX and RX flatness (± 0.3 dBm 200Hz - 4kHz). An alternative arrangement, using existing PCB sites, is shown in Fig. 7. Note, however, that TX flatness will be degraded with the topology.

CONSTRUCTION

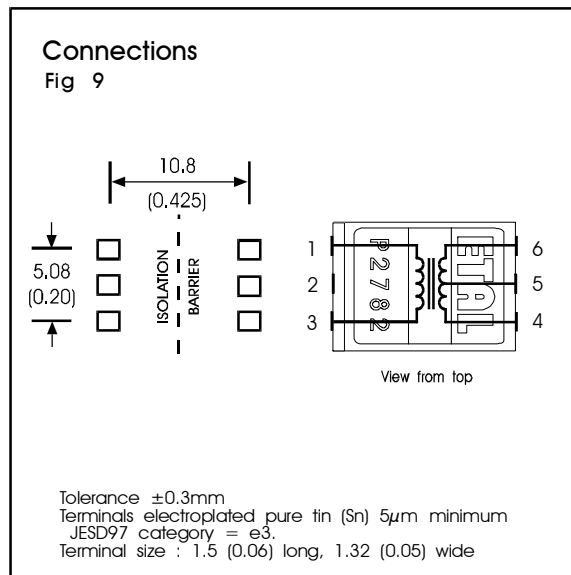
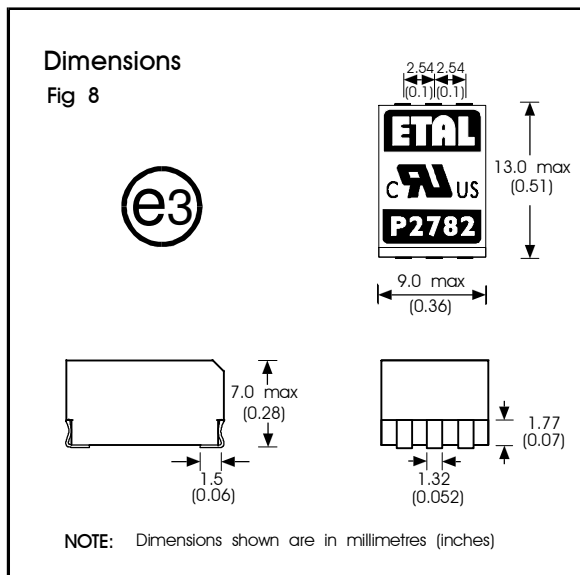

Dimensions shown are in millimetres (inches).

Geometric centres of outline and pad grid coincide within a tolerance circle of $0.3\text{mm}\varnothing$.

Observe correct orientation in circuit.

ABSOLUTE MAXIMUM RATINGS

(Ratings of components independent of circuit).

Short term isolation voltage (2s) 4.6 kVrms,
6.5kVDC

DC current 100 μA

Storage temperature -40°C to
 $+125^{\circ}\text{C}$

Soldering temperature
Profile peak 260 $^{\circ}\text{C}$ 10s

Recommended peak body temperature 245°C in
accordance with IPC/JEDEC J-STD-033.

COPYRIGHT

ETAL and P2782 are Trade Marks of Profec Technologies Ltd.

The Trade Mark ETAL is registered at the UK Trade Marks Registry.

Profec Technologies Ltd. is the owner of the design right under the Copyright Designs and Patents Act 1988 and no rights or licences are hereby granted or implied to any third party.

British Patent No. 2283195

US Patent No. 5879598

European Patent No. 0725719

© 1994 - 2005 Profec Technologies Ltd.
Reproduction prohibited.

SAFETY

Manufactured from materials conforming to flammability requirements of UL94V-0.

Distance through reinforced insulation 0.4mm minimum.

Creepage and clearances in circuit are 7mm minimum where PCB pads do not exceed 3mmØ.

Construction complies with IEC 60950-1, EN 60950-1 and UL 60950-1, reinforced insulation, 250Vrms maximum working voltage.

CERTIFICATION

Certified by BSI to IEC 60950 Third Edition (1999) (IEC CB Test Certificate No. GB592W) sub-clauses 1.5, 1.5.1, 1.5.2, 2.9, 2.9.1, 2.9.2, 2.9.3, 2.9.4, 2.9.5, 2.10, 2.10.1, 2.10.2, 2.10.3, 2.10.3.1, 2.10.3.2, 2.10.4, 2.10.5, 2.10.5.1, 2.10.7, 2.10.8, 4.7, 4.7.3, 4.7.3.1, 4.7.3.4, (Flammability Class V-0) 5.2, 5.2.1, and 5.2.2 for a maximum working voltage of 250Vrms, nominal mains supply voltage not exceeding 250Vrms and a maximum operating temperature of +85°C in Pollution Degree 2 environment, reinforced insulation.

Recognized under the Component Recognition Program of Underwriters Laboratories Inc. to US and Canadian requirements CAN/CSA C22.2 No. 60950-1-03/UL60950-1, First Edition, based on IEC 60950-1, First Edition, maximum working voltage 250Vrms, Pollution Degree 2, reinforced insulation.

UL File number E203175.

Additionally, Profec Technologies certifies all transformers as providing voltage isolation of 3.88kVrms, 5.5kV DC minimum. All shipments are supported by a Certificate of Conformity to current applicable safety standards.

ORDERING CODE

P2782□□

TR = Tape and Reel
(Blank) = Bulk in tubes.

Carrier tape width 24mm,
500 parts per 13" reel.



Profec Technologies Ltd., 10 Betts Avenue, Martlesham Heath, Ipswich, IP5 3RH, England

Telephone: +44 (0) 1473 611422

Website: www.profec.com

Fax: +44 (0) 1473 611919

Email: info@profec.co.uk sales@profec.com