

**MICROPROFILE LINE ISOLATING
HYBRID****P3000****Features**

- * Surface mount
- * Lead-free (Pb-free)
- * RoHS compliant
- * 7mm seated height
- * Low loss
- * Low Distortion
- * 2-4 wire conversion
- * IEC 950 and UL 60950 certified
- * UL Recognized Component

Applications

- * V.34, V.90 and V.92 Modems
- * Miniature DAA applications
- * Universal DAA applications
- * Notebook PC Fax/Modems
- * CODEC interface

DESCRIPTION

P3000 is a microprofile passive hybrid module for applications where reinforced insulation is required. It features fully vacuum encapsulated construction using materials conforming to UL94V-0 flammability requirements. The part is compliant with RoHS Directive 2002/95/EC, and suitable for lead-free and conventional placement and reflow.

P3000 performs the functions of reinforced safety barrier (3750Vrms), telephone line matching and 2-4 wire conversion. This component is designed specifically for high speed full-duplex data transmission where very low levels of distortion are required. High performance is achieved by realizing a very low noise floor at the receive port even when the power sourced at the transmit port is high. Circuit simplification is readily achieved as the transmit, receive and line ports are fully floating and galvanically isolated from each other.

P3000 is readily matched to complex reference impedances. The transmit and receive frequency responses are very flat (i.e. negligible 'twist') when matched to complex impedances.

For best operation the module requires a transmit drive from a high-quality low-impedance source ($\ll 10\Omega$), and a high impedance receive load (47k Ω nominal). These impedances may be directly provided by datapumps.

P3000 is also useful for voice applications requiring 2-4 wire conversion as its port impedances are particularly suitable for CODECs.

P3000 is certified to IEC 950 and UL 60950. P3000 is a UL Recognized Component, and is supported by an IEC CB Test Certificate.

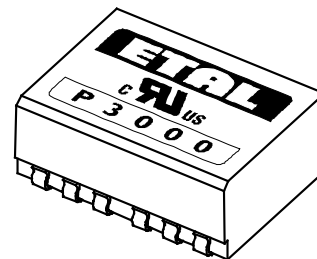
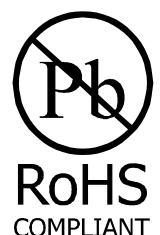
**Patented**

SPECIFICATIONS

Electrical

At T = 25°C and as reference circuit Fig. 2 unless otherwise stated.

Parameter	Conditions	Min	Typ	Max	Units
Insertion Loss	TX port (1,3) to line port (9,10)	-	1.8	-	dB
	TX port (1,3) to line terminals (matching loss included)	-	6.2	-	dB
	Line terminals to RX port (4,6)	-	2.8	-	dB
Frequency Response	TX port to line port 200Hz – 4kHz	-	±0.05	-	dB
	TX port to line terminals 300Hz – 3.4kHz	-	±0.1	-	dB
	Line terminals to RX port 300Hz – 3.4kHz	-	±0.1	-	dB
Transhybrid loss	300Hz – 3.4kHz	-	>30	-	dB
Return Loss	300Hz – 3.4kHz	-	>17	-	dB
Distortion ⁽¹⁾⁽²⁾					
TX signal splashback distortion at RX port					
Harmonic	Fundamental ≥600Hz @ 0dBm in line	-	≤-90	-	dBm
Intermodulation	Tones 1.5kHz, 2.1Hz total 0dBm in line	-	<-90	-	dBm
RX signal distortion at RX port					
Harmonic	Fundamental ≥600Hz @ 0dBm in line	-	≤-90	-	dBm
Intermodulation	Tones 1.5kHz, 2.1Hz total 0dBm in line	-	≤-90	-	dBm
TX signal distortion at line terminals					
Harmonic	Fundamental ≥600Hz @ 0dBm in line	-	≤-65	-	dBm
	Fundamental ≥600Hz @ -6dBm in line	-	≤-80	-	dBm
Intermodulation	Tones 1.5kHz, 2.1Hz total 0dBm in line	-	-70	-	dBm
Voltage Isolation ⁽³⁾	50Hz	3.88	-	-	kVrms
	DC	5.5	-	-	kV
Operating Range:	Ambient				
Functional		-25	-	+85	°C
Storage		-40	-	+125	°C
Humidity ⁽⁴⁾		-	-	95	%RH

Notes:

- For optimum distortion performance DC currents through pins 1 and 3 should not exceed 50µA, and currents through pins 4 and 6 should not exceed 3µA. DC resistance between pins 1-3, 115Ω nominal. DC resistance between pins 4-6, 1.6kΩ nominal.
- Caution:** do not pass DC through P3000. Telephone line current etc. must be diverted using semiconductor line hold circuit.
- Components are 100% tested at 6.5kVDC.
- Excludes shipping materials. Components are dry-packed and sealed as shipped. Handle in accordance with IPC/JEDEC J-STD-033 procedure for components classified as IPC/JEDEC J-STD-020 Moisture Sensitivity Level 5a.

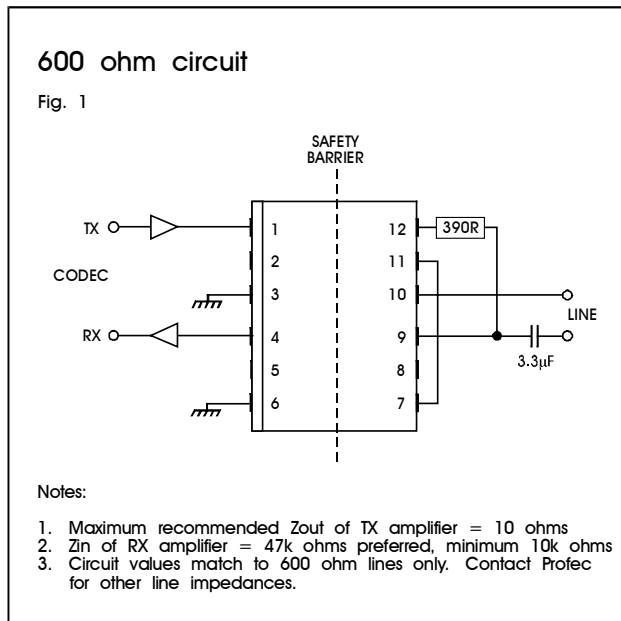

CONSTRUCTION

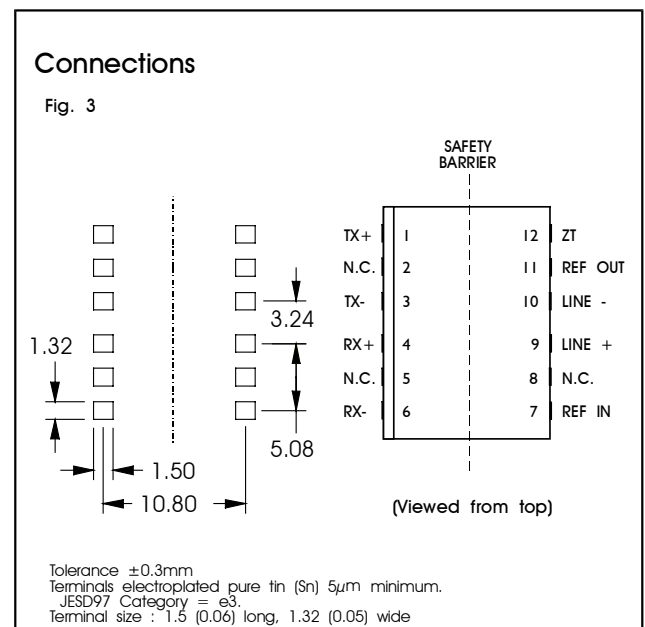
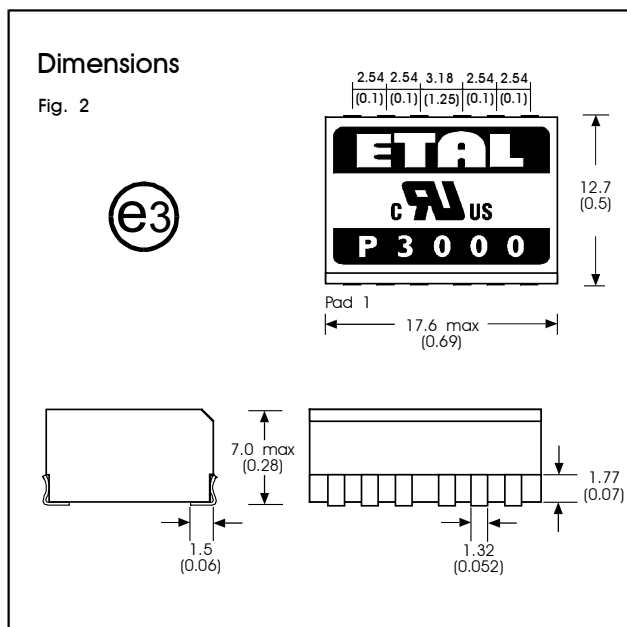

Dimensions shown are in millimetres (inches).
 Geometric centres of outline and pad grid coincide within a tolerance circle of $0.6\text{mm}\varnothing$.

SAFETY

Manufactured from materials conforming to flammability requirements of UL94V-0. Distance through reinforced insulation 0.4mm minimum.

Creepage and clearances in circuit are 7mm minimum where PCB pads do not exceed 3mmØ.

Construction complies with IEC 60950-1, EN 60950-1 and UL 60950-1, reinforced insulation, 250Vrms maximum working voltage.

ABSOLUTE MAXIMUM RATINGS

(Ratings of components independent of circuit).

Short term isolation voltage (2s)	4.6 kVrms, 6.5kVDC
DC current	100µA
Storage temperature	-40°C to +125°C
Soldering temperature Profile peak	260°C 10s
Recommended peak body temperature	245°C in accordance with IPC/JEDEC J-STD-033.

CERTIFICATION

Certified by BSI to IEC 950:1991/A4:1996 (IEC CB Test Certificate No. GB441W) sub-clauses 1.5, 1.5.1, 1.5.3, 2.2, 2.2.2, 2.2.3, 2.2.4, 2.9.2, 2.9.3, 2.9.4, 2.9.6, 2.9.7, 4.4, 4.4.3.2 (class V-0) and 5.3 for a maximum working voltage of 250Vrms, nominal mains supply voltage not exceeding 250Vrms and a maximum operating temperature of +85°C in Pollution Degree 2 environment, reinforced insulation.

Recognized under the Component Recognition Program of Underwriters Laboratories Inc. to US and Canadian requirements CAN/CSA C22.2 No. 60950-1-03/UL60950-1, First Edition, based on IEC 60950-1, First Edition, maximum working voltage 250Vrms, Pollution Degree 2, reinforced insulation.

UL File number E203175.

Additionally, Profec Technologies certifies all transformers as providing voltage isolation of 3.88kVrms, 5.5kV DC minimum. All shipments are supported by a Certificate of Conformity to current applicable safety standards.

ORDERING CODE

P3000 

TR = Tape and Reel
(Blank) = Bulk in tubes.

Carrier tape width 32mm,
400 parts per 13" reel.

INTELLECTUAL PROPERTY RIGHTS

ETAL, and P3000 are Trade Marks of Profec Technologies Ltd.

The Trade Mark ETAL is registered at the UK Trade Marks Registry.

The concept, design and circuit embodiment of components such as P3000 are patented. No patent rights or licences to any circuits or products described herein are implied or granted to any third party.

British Patent No. 2270241 and 2283195

France Patent No. 9310408

European Patent No. 0725719

US Patent No. 5426697 and 5879598

Germany Patent No. DE 4329519

© 1997 - 2005 Profec Technologies Ltd.

Reproduction prohibited.



ISO 9001
FM 25326

Profec Technologies Ltd., 10 Betts Avenue, Martlesham Heath, Ipswich, IP5 3RH, England

Telephone: +44 (0) 1473 611422

Website: www.profec.com

Fax: +44 (0) 1473 611919

Email: info@profec.co.uk sales@profec.com