

LINE MATCHING TRANSFORMER**P5122****Features**

- * Lead-free (Pb-free)
- * RoHS compliant
- * 11mm (0.43") seated height
- * Industry Standard Pinout
- * IEC 60950 and UL 60950 Certified
- * High thermal stability

Applications

- * Set Top Boxes
- * Telecommunications
- * Voice
- * Least-cost routers
- * V.22bis

DESCRIPTION

P5122 is intended for low-cost, low-speed data and voice applications. It is a direct substitute for industry standard P3189, being mechanically compatible and having identical signal/distortion and matching characteristics, and is suitable for supplementary insulation, 250V working.

P5122 uses patented design and construction methods to achieve excellent signal performance and safety isolation to international standards. P5122 is certified to IEC 60950 and UL 60950. P5122 is a UL Recognized Component and is supported by an IEC CB certificate. The part is completely lead-free, compliant with RoHS Directive 2002/95/EC, and suitable for lead-free and conventional processing.

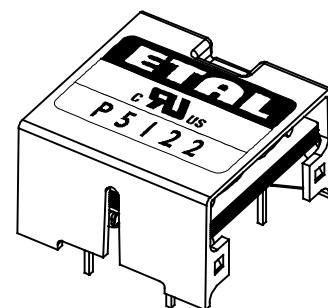
**Patented**

SPECIFICATIONS

Electrical

At T = 25°C and as circuit fig. 2 unless otherwise stated.

Parameter	Conditions	Min	Typ	Max	Units
Insertion Loss	f = 2kHz, R _L = 560Ω	-	-	1.5	dB
Frequency response	200Hz - 4kHz	-	-	±0.2	dB
Return Loss	200Hz - 4kHz	18	-	-	dB
Third Harmonic Distortion ⁽¹⁾	300Hz - 6dBm 697Hz - 6dBm	- -	- -	-62 -70	dBm dBm
Voltage isolation ⁽²⁾	50Hz	2.12	-	-	kVrms
	DC	3.0	-	-	kV
Operating range:	Ambient temperature				
Functional		0	-	+70	°C
Storage		-40	-	+85	°C

Lumped equivalent circuit parameters as Fig. 1

DC resistance, R _{DC} ⁽³⁾	Sum of windings	124	-	152	Ω
Leakage inductance ΔL		14.5	-	18	mH
Shunt inductance L _p ⁽⁴⁾	10mV 200Hz	1.4	-	-	H
Shunt loss R _p ⁽⁴⁾	10mV 200Hz	4	-	-	kΩ

Notes

1. Third harmonic typically exceeds other harmonics by 20dB.
2. Components are 100% tested at 3.25kV DC.
3. Caution: do not pass DC through windings. Telephone line current, etc. must be diverted using choke or semiconductor line hold circuit.
4. At signal levels greater than 100mV, L_p will increase and R_p will decrease slightly but the effect is usually favourable to the return loss characteristic.

Equivalent Circuit

Fig. 1

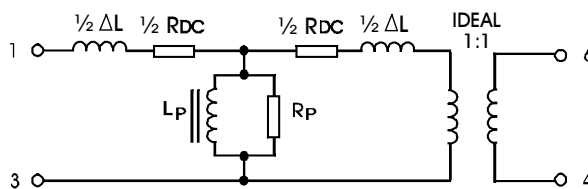

Patented

MATCHING RECOMMENDATIONS

600Ω MATCH

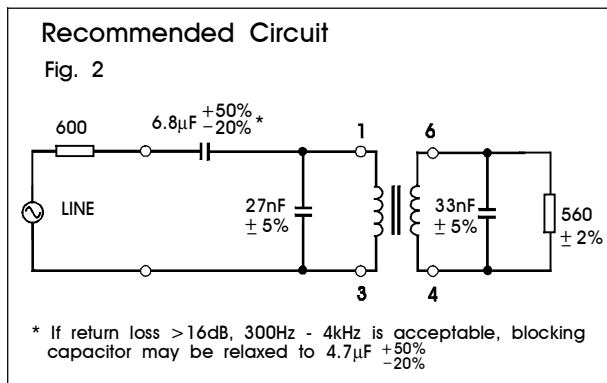
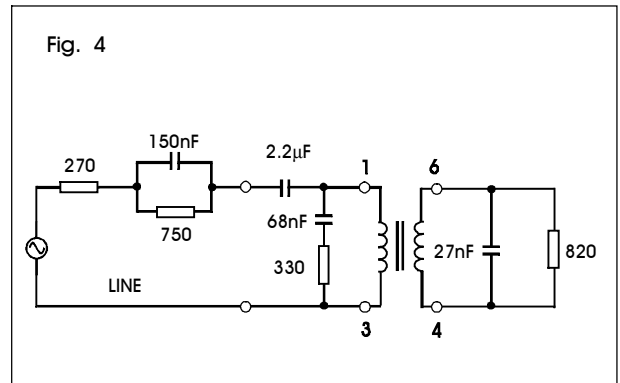
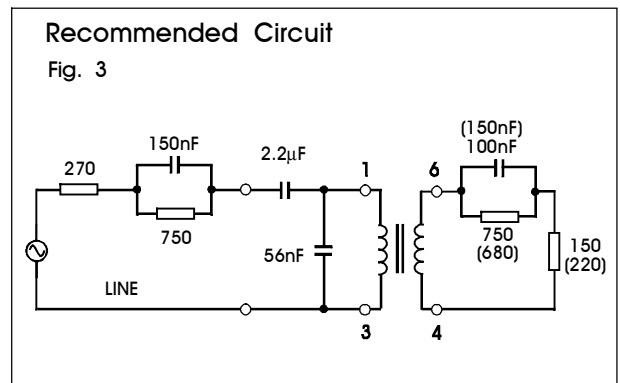

Figure 3 gives flat RX and TX responses against the CTR21 complex reference impedance (typically around ± 0.5 dB 300Hz - 3.4kHz). Return loss is typically better than 20dB. The circuit values in parentheses give optimum flatness at a small sacrifice in return loss.

For circuits with existing board drillings, figure 4 gives good return loss (>20dB) and RX flatness against the CTR21 complex reference impedance, but TX flatness is degraded by the use of this topology.

EUROPEAN CTR21 COMPLEX MATCH



CONSTRUCTION

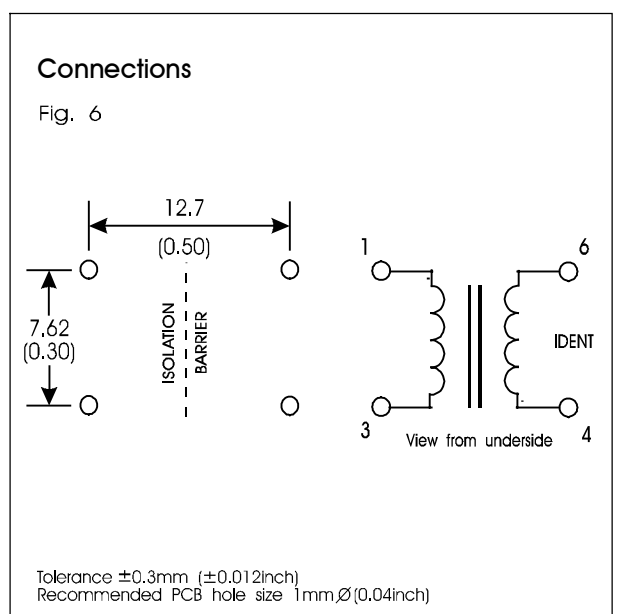
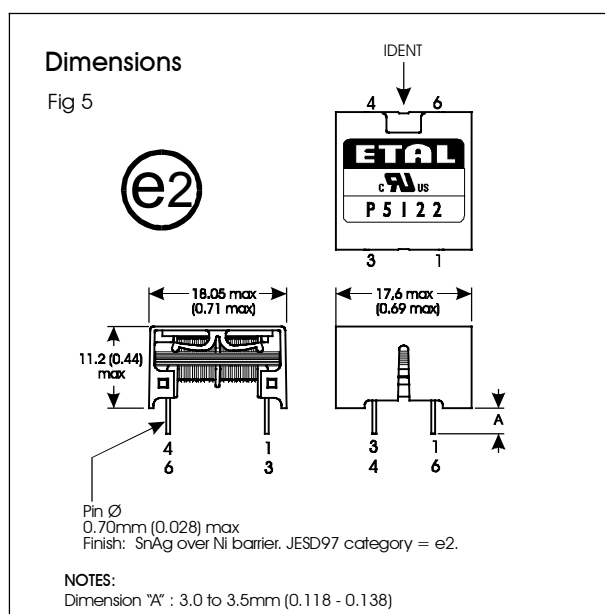

Dimensions shown are in millimetres (inches).
Geometric centres of outline and pin grid coincide within a tolerance circle of 0.6mm
Windings may be used interchangeably as primary or secondary.

SAFETY

Constructed in accordance with IEC 60950-1, EN 60950-1 and UL 60950-1, supplementary insulation, 250Vrms maximum working voltage, flammability class V-0.

CERTIFICATION

Certified under the IEC CB scheme (Certificate GB605W) to IEC 60950 Third Edition 1999 sub-clauses 1.5, 1.5.1, 1.5.2, 2.9, 2.9.1, 2.9.2, 2.9.3, 2.9.4, 2.9.5, 2.10, 2.10.1, 2.10.2, 2.10.3, 2.10.3.1, 2.10.3.2, 2.10.4, 2.10.5, 2.10.5.1, 2.10.5.4, 4.7, 4.7.3, 4.7.3.1, 4.7.3.4, (Flammability Class V-0), 5.2, 5.2.1, and 5.2.2 for a maximum working voltage of 250Vrms, nominal mains supply voltage not exceeding 300Vrms and a maximum operating temperature of +85°C in Pollution Degree 2 environment, supplementary insulation for a primary circuit.

Recognized under the Component Recognition Program of Underwriters Laboratories Inc. to US and Canadian requirements CAN/CSA C22.2 No. 60950-1-03/UL60950-1, First Edition, based on IEC 60950-1, First Edition, maximum working voltage 250Vrms, Pollution Degree 2, supplementary insulation.

UL File number E203175.

Additionally, Profec Technologies certifies all transformers as providing voltage isolation of 2.12kVrms, 3kV DC minimum. All shipments are supported by a certificate of conformity to current applicable safety standards.

ABSOLUTE MAXIMUM RATINGS

(Ratings of components independent of circuit).

Short term isolation voltage (1s)	2.12kVrms 3.0kVDC
DC current	100µA
Storage temperature	-40°C to +85°C
Lead temperature, 10s	260°C

INTELLECTUAL PROPERTY RIGHTS

ETAL, P5122 and P3189 are Trade Marks of Profec Technologies Ltd.

The Trade Mark ETAL is registered at the UK Trade Marks Registry.

Profec Technologies Ltd. is the owner of the design right under the Copyright Designs and Patents Act 1988 and no rights or licences are hereby granted or implied to any third party.

P5122 design and construction are protected by patents.
USA Patent No. 6,690,254.
Other patents pending.

© 1998 - 2005 Profec Technologies Ltd.
Reproduction prohibited.



ISO 9001
FM 25326

Profec Technologies Ltd., 10 Betts Avenue, Martlesham Heath, Ipswich, IP5 3RH, England

Telephone: +44 (0) 1473 611422

Website: www.profec.com

Fax: +44 (0) 1473 611919

Email: info@profec.co.uk sales@profec.com