

**PLANAR POWER TRANSFORMER****P6141****Features**

- \* Planar windings
- \* 4mm height above PCB
- \* Low leakage inductance
- \* High frequency operation
- \* Externally configurable
- \* Centre-tapped secondaries
- \* Lead-free (Pb-free)

**Applications**

- \* DC-DC converters
- \* Forward converters
- \* 48V or 24V inputs
- \* 5V @ 5A output
- \* 3.3V @ 7A output

---

**DESCRIPTION**

P6141 is a planar power transformer using multilayer PCB technology. It is intended for low profile high frequency DC-DC forward converters up to 500kHz. With careful design, output power exceeding 30W is achievable.

P6141 has split primaries and secondaries enabling the device to be configured for 48V and 24V inputs and 5V or 3.3V outputs.

The contacts to the host circuit board are made by solder connection to large plated-through holes in the P6141 PCB, thus ensuring low resistance connection. The ferrite is intended to sit within a PCB cut-out, giving a height above board of 4mm.

P6141 is lead-free (Pb-free) and suitable for conventional and lead-free processing.

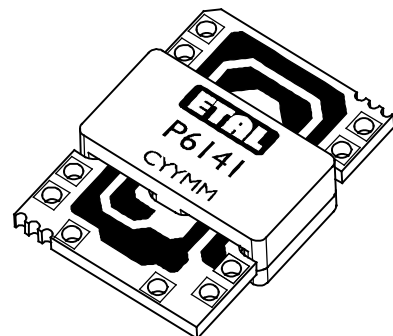

## SPECIFICATIONS

### Electrical

Typical values at T = 25°C, unless otherwise stated.

Parameter	Conditions	Min	Typ	Max	Units
Primary Inductance	100kHz, 100mV Each primary winding 2-9, 1-10	17	25	35	μH
Leakage Inductance	500kHz, 100mV (1, 2) – (9, 10) link 3, 4, 5, 6, 7, 8	-	-	100	nH
Primary/Secondary voltage isolation	(1+2):3	500	-	-	Vrms
Interwinding capacitance	100kHz, 1V primary : secondary	-	308	-	pF
Total transformer losses	Vout = 5V at Iout = 5A or Vout = 3.3V at Iout = 7A 400kHz	-	0.7	-	W
DCR	Primaries 2-9, 1-10	17	20	23	mΩ
	3-5, 6-8	-	7.5	-	mΩ
Turns Ratio	(1-10):(2-9)	-	1.0	-	-
	(5-3):(8-6)	-	1.0	-	-
	(1-10):(5-3)	-	1.5	-	-
	(2-9):(8-6)	-	1.5	-	-
Operating range:	Ambient temperature	-40	-	+85	°C
		Functional	-40	-	+85
Storage		-40	-	+85	°C

### Typical Magnetic Core Coefficients

C <sub>1</sub>	Core factor	0.514mm <sup>-1</sup>
V <sub>e</sub>	Effective volume	800mm <sup>3</sup>
l <sub>e</sub>	Effective length	20.3mm
A <sub>e</sub>	Effective area	39.5mm <sup>2</sup>
μ <sub>e</sub>	Effective permeability	1270
m	Mass	4.1g

Transformer schematic

Fig 1

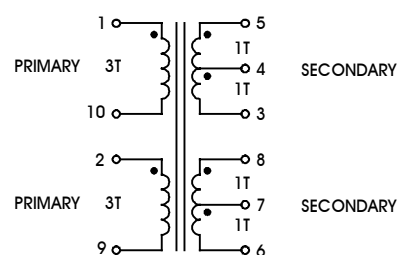

## CONSTRUCTION

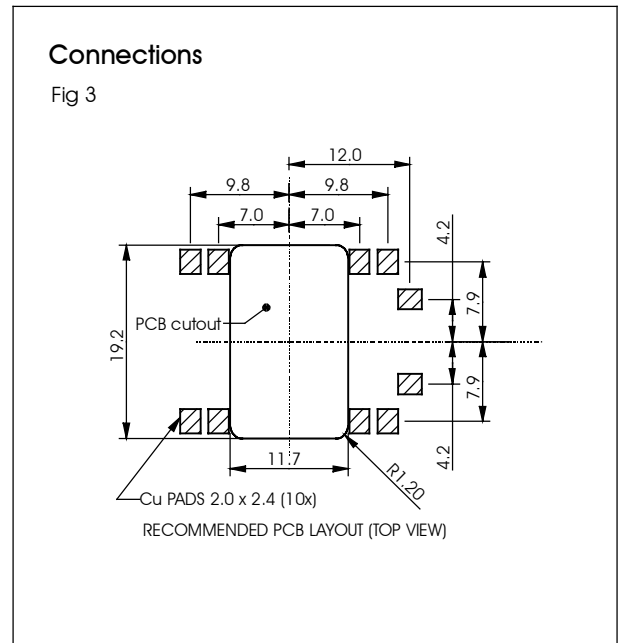
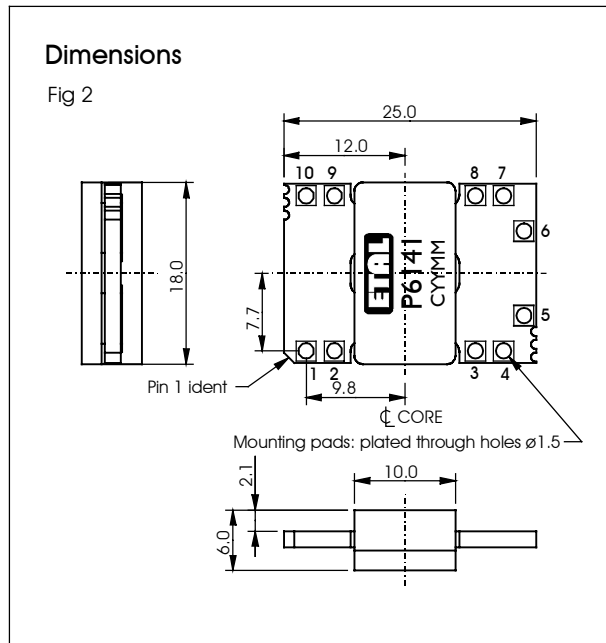

Dimensions shown are in millimetres.  
Terminal finish is 0.1  $\mu\text{m}$  max gold (Au) over nickel (Ni).

## APPLICATION SCHEMATICS

P6141 is designed for forward converter applications where power is coupled from the primary to secondary circuits during the 'on' time of the switch. Unlike the flyback converter, the forward converter transformer is not designed as a storage element, and thus the ferrite core is ungapped.

In the single quadrant operation forward converter, some means must be provided to 'reset' the flux due to the build up of magnetizing current in the device, and since P6141 does not have a reset winding, this function must be provided externally.

There are several methods for providing the reset function in the absence of a reset winding. The first, shown in fig 4, uses a zener diode to perform the reset function. This has the advantage of simplicity; however, energy is wasted in the reset circuit, and there is a constraint on the duty cycle that must be observed.

An alternative circuit is shown in fig 5, where two synchronized switches are used. This has the advantage that energy is returned to the supply; however, the duty factor is limited to 0.5.

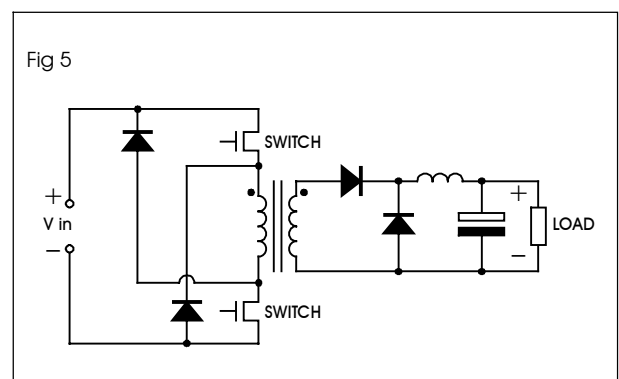
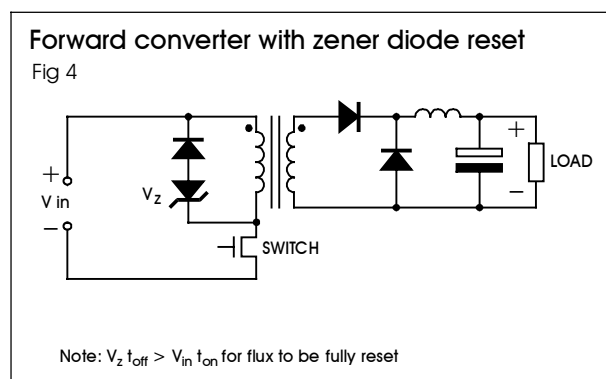

## Input voltage setting

For 48V operation, the P6141 primaries are connected in series, giving a nominal inductance of 100 $\mu$ H and primary DCR 41m $\Omega$ . For 24V operation, the primaries are connected in parallel, giving a nominal primary inductance of 25 $\mu$ H and primary DCR of 10m $\Omega$

## Output voltage setting

For 5V output, the P6141 secondaries are connected in series, giving a secondary DCR of 15m $\Omega$ . For 3.3V operation, the secondaries are connected in parallel, giving a secondary DCR of 3.8m $\Omega$ .

Figs 6-9 show forward converter topologies with input voltages 48V and 24V and output voltages 5V and 3.3V.

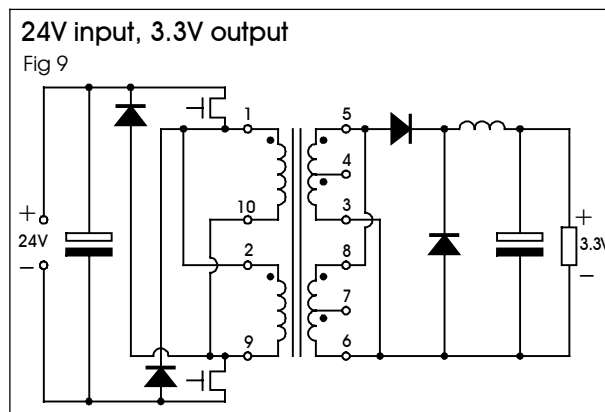
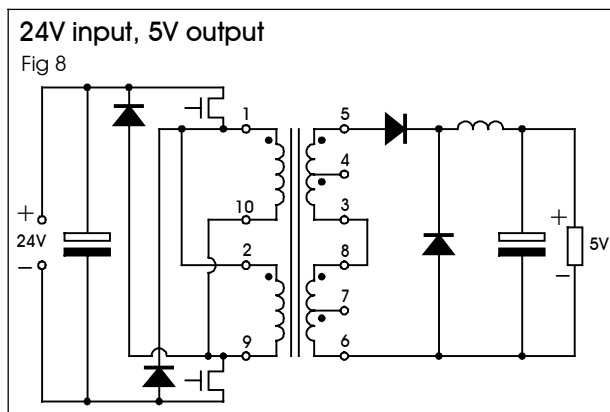
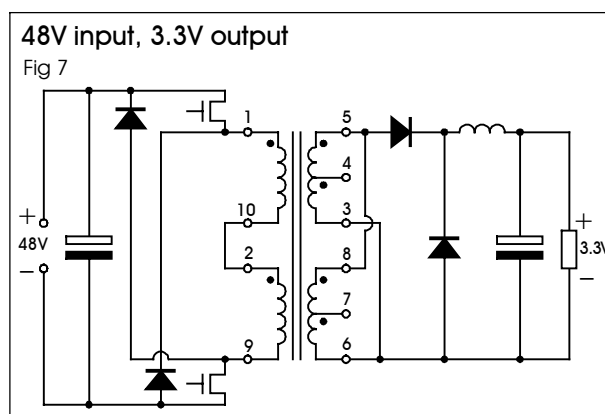
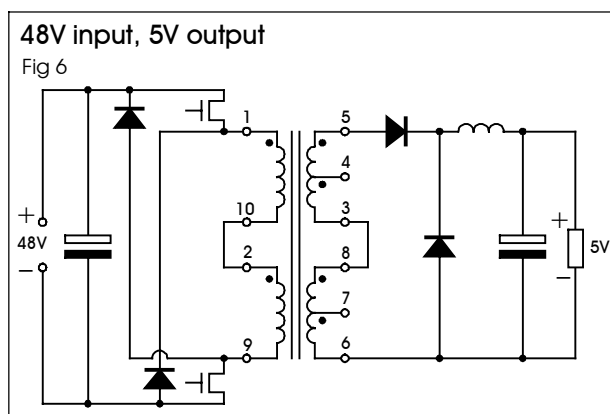

For frequencies from 300–500kHz and output currents from 1–5A (5V output) and 1.5–7A (3.3V output) suitable low profile output inductors (height 4mm) can be found in the ETAL P7602-1003 range. See below for choice of output inductor.

### Output inductor

Unless they are current fed, forward converters require output inductors.

Suitable standard power inductors are available from the ETAL range. The inductor must satisfy a number of criteria (apart from mechanical considerations) as follows:-

1. Minimum inductance.

It is essential that the current through the inductor does not fall to zero, which places a constraint that the pk-pk ripple current must not exceed twice the minimum output current. Once the minimum output current ( $I_{out}$ ) is defined, the minimum inductance ( $L_{min}$ ) as a function of frequency ( $f$ ) and output voltage ( $V_{out}$ ) can be defined thus:

$$L_{min} \approx \frac{0.3V_{out}}{I_{out (min)} f}$$

2. Energy storage.

The inductor must be able to store sufficient energy without saturation.

Energy storage is given by:  $\frac{1}{2}LI_{out}^2$

Profec publishes application data on its ETAL inductors showing, by product family, typical inductance ranges and storage energies.

As a check, it is worth verifying from individual datasheets that maximum current (maximum load current + ripple current) does not exceed the saturation current rating.

As an example, for the 5V/5A output and minimum output current of 1A with switching frequency 400kHz, the minimum inductance calculated is 3.75 $\mu$ H and energy storage requirement 47 $\mu$ J.

A low profile (4mm) shielded power inductor P7602-1003-3R8Y will be suitable. It has the following characteristics:

L = 3.8 $\mu$ H  
I<sub>sat</sub> = 6A  
Energy = 68.4 $\mu$ J

### **ORDERING CODE**

P6141T  
└───┬─── Tape and Reel  
    └─── (400 parts per 13" reel)  
    └─── Type code

### **ABSOLUTE MAXIMUM RATINGS**

(Ratings of components independent of circuit).

Short term isolation voltage (1s)	500Vrms
V. $\mu$ s per primary winding	16V. $\mu$ s (for $\Delta B=135mT$ )
Storage temperature	+85°C
Magnetic Core temperature	120°C
Reflow temperature (10s)	260°C

**PROFEC**  
TRANSFORMING THE FUTURE



ISO 9001  
FM 25326

Profec Technologies Ltd., 10 Betts Avenue, Martlesham Heath, Ipswich, IP5 3RH, England

Telephone: +44 (0) 1473 611422

Fax: +44 (0) 1473 611919

Website: [www.profec.com](http://www.profec.com)

Email: [info@profec.co.uk](mailto:info@profec.co.uk) [sales@profec.com](mailto:sales@profec.com)