

**LOW PROFILE LINE
MATCHING TRANSFORMER****P3065****Features**

- * Low Distortion
- * Lead-free (Pb-free)
- * RoHS compliant
- * Low Profile (11mm)
- * Vacuum encapsulated
- * IEC 60950 and UL 60950 certified
- * UL Recognized Component
- * High Thermal Stability

Applications

- * V.34 modems
- * Data rates to 33.6kbps
- * Line matching
- * Portable computers
- * Fax/modems
- * Instrumentation

DESCRIPTION

P3065 is intended for data communications to 33,600 bits/second data rates. P3065 is specifically designed to be easily matched to both 600 ohm and complex impedance telephone lines, using a minimum of external components.

P3065 also exhibits stable characteristics over its operating temperature range to maximize data throughput under varying environmental conditions without the need for modem retraining.

P3065 is certified to IEC 60950 and UL 60950. P3065 is a UL Recognized Component, and is supported by an IEC CB Test Certificate. The part is completely lead-free, compliant with RoHS Directive 2002/95/EC, and suitable for lead-free and conventional processing.

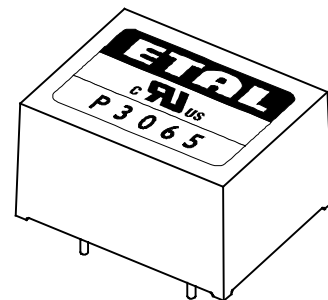

SPECIFICATIONS

Electrical

At T = 25°C and as circuit Fig. 2 unless otherwise stated.

Parameter	Conditions	Min	Typ	Max	Units	
Insertion Loss	f = 2kHz, R _L = 470Ω	-	2.5	3.0	dB	
Frequency Response	LF -3dB cutoff	-	30	-	Hz	
	HF -3dB cutoff	-	15	-	kHz	
	200Hz - 4kHz	-	-	±0.2	dB	
Return Loss	200Hz - 4kHz	16	-	-	dB	
Distortion ⁽¹⁾	0dBm in line, 3rd Harmonic f = 600Hz	-	-85	-80	dBm	
	-10dBm in line, 3rd Harmonic f = 600Hz	-	-100	-95	dBm	
Balance	DC - 5kHz	80	-	-	dB	
Saturation	Excitation 50Hz 250Vrms.	-	-	10	Vrms	
	Output voltage across line	-	-	65	Vpeak	
Voltage isolation ⁽²⁾	50Hz	3.88	-	-	kVrms	
	DC	5.5	-	-	kV	
Operating range:	Ambient temperature	Functional	-25	-	+85	°C
		Storage	-40	-	+125	°C
		Humidity	-	-	95	%R.H.

Lumped equivalent circuit parameters as Fig. 1

DC resistance, R _{DC} ⁽³⁾	Sum of windings	170	-	210	Ω
Leakage inductance ΔL		-	20	-	mH
Shunt inductance L _p ⁽⁴⁾	100mV 200Hz	3.5	6	16	H
	100mV 1kHz	-	4	-	H
Shunt loss R _p ⁽⁴⁾	10mV 200Hz	12	-	-	kΩ
	10mV 1kHz	18	-	-	kΩ

Notes

- Third harmonic typically exceeds other harmonics by 10dB.
- Components are 100% tested at 6.5kV DC.
- Caution: do not pass DC through windings. Telephone line current, etc. must be diverted using semiconductor line hold circuit.
- At signal levels greater than 100mV, L_p will increase and R_p will decrease slightly but the effect is usually favourable to the return loss characteristic.

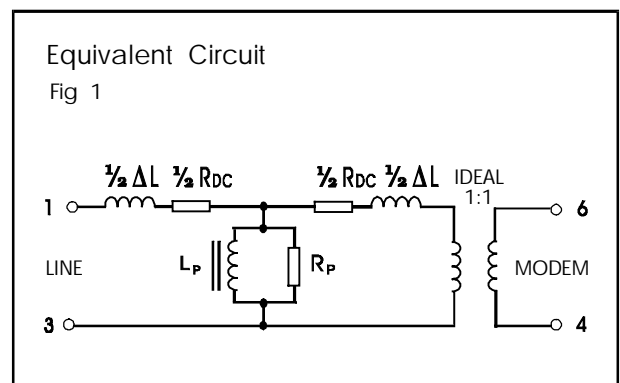

PERFORMANCE CHARACTERISTICS

600Ω MATCH

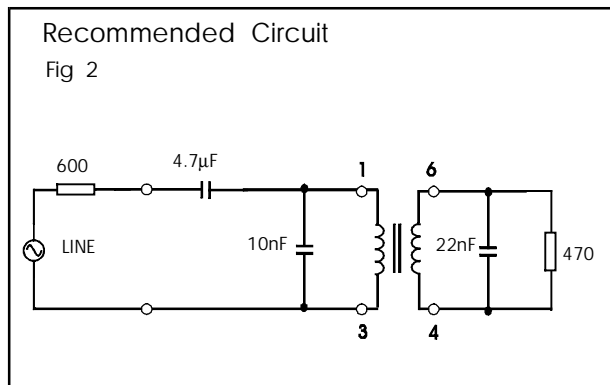

EUROPEAN CTR21 COMPLEX MATCH

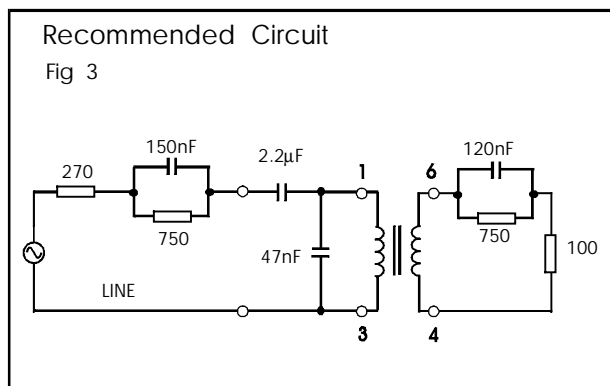
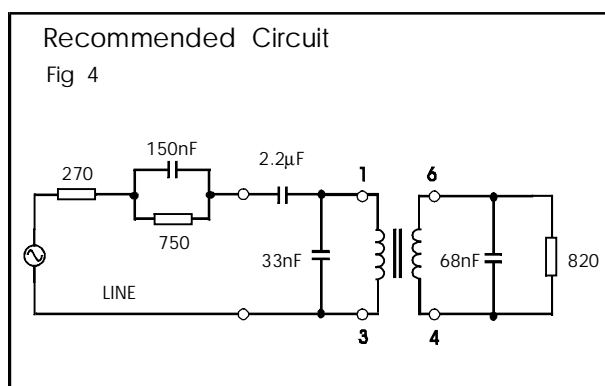

Figure 3 gives flat RX and TX responses against the reference impedance (typically around $\pm 0.5\text{dB}$ 300Hz - 3.4kHz). Return loss is typically better than 20dB. The 120nF capacitor should be of a temperature stable dielectric. In practice, the 100ohm resistor will normally connect to a low impedance TX output.

For circuits with existing board drillings, figure 4 gives good return loss ($>20\text{dB}$) against the reference impedance, but TX and RX flatness are degraded by the use of this topology.



In practice, the 820ohm resistor will normally connect to a low impedance TX output. The 68nF capacitor, which should be of a temperature stable dielectric, should be placed in parallel with the 820ohm resistor (rather than in parallel with the transformer winding) to obtain good TX flatness.

For recommended matching to other reference impedances please contact Profec Technologies.

CONSTRUCTION

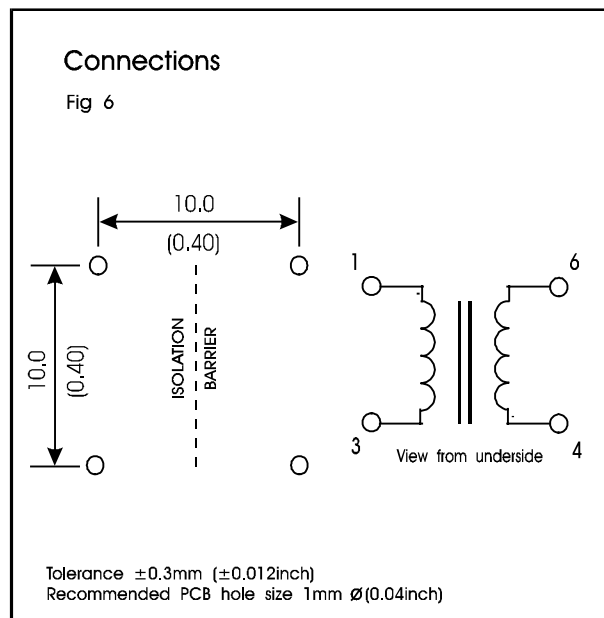
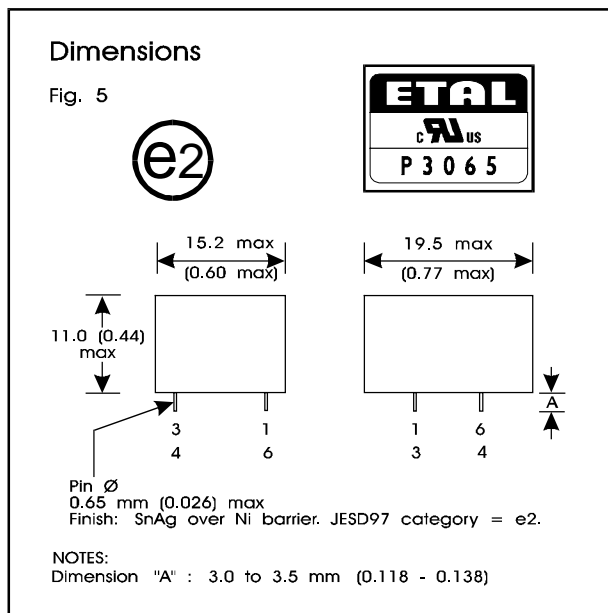

Dimensions shown are in millimetres (inches).

Geometric centres of outline and pin grid coincide within a tolerance circle of 0.6mm \varnothing .

Windings may be used interchangeably as primary or secondary.

SAFETY

Constructed in accordance with IEC 60950-1:2001, EN60950-1:2001, and UL 60950-1 First Edition, supplementary insulation, 250Vrms maximum working voltage, flammability class V-0.

Distances through solid insulation 0.4mm minimum.

CERTIFICATION

Certified under the IEC CB scheme (Certificate DK-9431) to IEC 60950-1:2001, sub-clauses 1.5, 1.5.1, 1.5.2, 1.7, 1.7.1, 2, 2.9, 2.9.1, 2.9.2, 2.9.3, 2.10, 2.10.1, 2.10.2, 2.10.3, 2.10.3.1, 2.10.3.3, 2.10.4, 2.10.5, 2.10.5.1, 2.10.5.4, 4, 4.7, 4.7.1, 4.7.3, 4.7.3.1, 4.7.3.4, 5, 5.2, 5.2.1, and 5.2.2 for a maximum working voltage of 250Vrms, nominal mains supply voltage not exceeding 300Vrms and a maximum operating temperature of 85°C in Pollution Degree 2 environments, supplementary insulation, including national differences for Denmark, Finland, Germany, Norway, Sweden, Switzerland, USA, Canada and UK.

Recognized under the Component Recognition Program of Underwriters Laboratories Inc. to US and Canadian requirements CAN/CSA C22.2 No. 60950-1-03/UL60950-1, First Edition, based on IEC 60950-1, First Edition, maximum working voltage 250Vrms, Pollution Degree 2, reinforced insulation.

UL File number E203175.

Additionally, Profec Technologies certifies all transformers as providing voltage isolation of 3.88kVrms, 5.5kV DC minimum. All shipments are supported by a Certificate of Conformity to current applicable safety standards.

ABSOLUTE MAXIMUM RATINGS

(Ratings of components independent of circuit).

Short term isolation voltage (2s)	4.6kVrms, 6.5kVDC
DC current	100 μ A
Storage temperature	-40°C to +125°C
Lead temperature, 10s	260°C

COPYRIGHT

ETAL and P3065 are Trade Marks of Profec Technologies Ltd.

The Trade Mark ETAL is registered at the UK Trade Marks Registry.

Profec Technologies Ltd. is the owner of the design right under the Copyright Designs and Patents Act 1988 and no rights or licences are hereby granted or implied to any third party.

© 1997-2006 Profec Technologies Ltd.
Reproduction prohibited.



ISO 9001
FM 25326

Profec Technologies Ltd., 10 Betts Avenue, Martlesham Heath, Ipswich, IP5 3RH, England

Telephone: +44 (0) 1473 611422

Website: www.profec.com

Fax: +44 (0) 1473 611919

Email: info@profec.co.uk sales@profec.com